

Filament & L.V. Rectifier Use - Single Primary (166 Series)

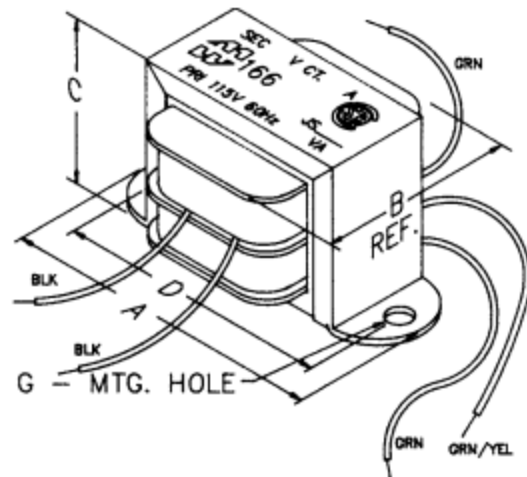

OPEN STYLE FILAMENT & L.V. RECTIFIER USE TRANSFORMERS

- Economical single primary 115 VAC, 60 Hz. or 117 VAC, 50/60 Hz. (see tables). If you require dual primary 117/234 operation, see our 266 series)
- All secondaries center tapped, VAC (RMS)
- Open style, channel bracket, two hole chassis mount.
- Minimum 6" long leads.
- Dual bobbin design - no electrostatic shield required.
- We use Class B insulation (130 degrees, C) for extra protection - UL listed as a Class A (105 degree, C) design.
- Hi-Pot test of 2,000V RMS.
- UL listed.
- CSA certified.



Dimension Table "C" Mount

Mtg. Style	Dimensions (Inches)				Mtg. Hole (Inches)
	A	B	C	D	
C0H	1.35	0.69	0.69	1.06	0.125
C1H	1.63	0.88	0.81	1.38	0.125
C2H	2.06	1.25	1.19	1.75	0.187
C3H	2.06	1.38	1.19	1.75	0.187
C4H	2.38	1.38	1.38	2.00	0.187
C5H	2.38	1.50	1.38	2.00	0.187
C6H	2.81	1.50	1.69	2.38	0.187
C7H	2.81	1.63	1.69	2.38	0.187
C8H	3.25	1.63	2.00	2.81	0.187
C9H	3.25	1.75	2.00	2.81	0.187
C10H	3.25	2.00	2.00	2.81	0.187
C11H	3.69	1.88	2.31	3.13	0.187
C12H	3.69	2.00	2.31	3.13	0.187
C13H	3.69	2.13	2.31	3.13	0.187
C14H	4.03	2.25	2.63	3.56	0.187
C15H	4.03	2.50	2.63	3.56	0.187
C16H	4.50	2.50	3.00	4.00	0.203

Transformer Schematic

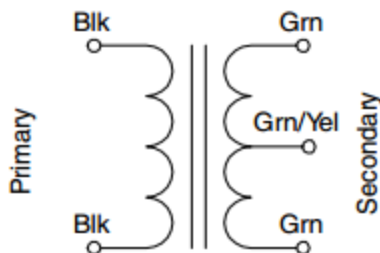



Part No.	VA	Primary	Secondary (R.M.S.)		Dim Ref.
			VAC	Amps	
166F2	0.63	115 V 60 Hz.	2.5 C.T.	0.25	C2H
166G2	1.25	115 V 60 Hz.	2.5 C.T.	0.5	C2H
166J2	2.5	115 V 60 Hz.	2.5 C.T.	1	C3H
166K2	3.75	115 V 60 Hz.	2.5 C.T.	1.5	C4H
166L2	6.25	115 V 60 Hz.	2.5 C.T.	2.5	C6H
166M2	7.5	115 V 60 Hz.	2.5 C.T.	3	C6H
166Q2	15	115 V 60 Hz.	2.5 C.T.	6	C8H
166S2	25	115 V 60 Hz.	2.5 C.T.	10	C12H
166F5	1.25	115 V 60 Hz.	5 C.T.	0.25	C2H
166G5	2.5	115 V 60 Hz.	5 C.T.	0.5	C3H
166J5	5	115 V 60 Hz.	5 C.T.	1	C5H
166L5	10	115 V 60 Hz.	5 C.T.	2	C7H
166MS	15	115 V 60 Hz.	5 C.T.	3	C9H
166R5	40	115 V 60 Hz.	5 C.T.	8	C12H
166RS	40	115 V 60 Hz.	5 C.T.	8	C16H
166S5	50	115 V 60 Hz.	5 C.T.	10	C13H
166U5	75	115 V 60 Hz.	5 C.T.	15	C14H
166V5	100	115 V 60 Hz.	5 C.T.	20	C16H
166E6	0.95	115 V 60 Hz.	6.3 C.T.	0.15	C2H
166F6	1.89	115 V 60 Hz.	6.3 C.T.	0.3	C3H
166G6	3.78	115 V 60 Hz.	6.3 C.T.	0.6	C4H
166J6	6.3	115 V 60 Hz.	6.3 C.T.	1	C6H
166K6	7.56	115 V 60 Hz.	6.3 C.T.	1.2	C6H
166K6B	7.56	117 V 50/60 Hz.	6.3 C.T.	1.2	C6H
166L6	12.6	115 V 60 Hz.	6.3 C.T.	2	C7H
166M6	18.9	117 V 50/60 Hz.	6.3 C.T.	3	C10H
166N6	25.2	115 V 60 Hz.	6.3 C.T.	4	C9H
166Q6	37.8	115 V 60 Hz.	6.3 C.T.	6	C12H
166S6	63	115 V 60 Hz.	6.3 C.T.	10	C14H
166G7	4.9	115 V 60 Hz.	7 C.T.	0.7	C5H
166U7	112.5	115 V 60 Hz.	7.5 C.T.	15	C16H
166G8	4	115 V 60 Hz.	8 C.T.	0.5	C4H
166J8	8.5	115 V 60 Hz.	8.5 C.T.	1	C6H
166L8	17	115 V 60 Hz.	8.5 C.T.	2	C8H
166M8	25.5	115 V 60 Hz.	8.5 C.T.	3	C9H
166N8	34	115 V 60 Hz.	8.5 C.T.	4	C10H
166G9	4.5	115 V 60 Hz.	9 C.T.	0.5	C4H
166F10	3	115 V 60 Hz.	10 C.T.	0.3	C3H
166G10	5	115 V 60 Hz.	10 C.T.	0.5	C5H
166J10	10	115 V 60 Hz.	10 C.T.	1	C7H
166L10	20	115 V 60 Hz.	10 C.T.	2	C9H
166M10	30	115 V 60 Hz.	10 C.T.	3	C10H
166N10	40	115 V 60 Hz.	10 C.T.	4	C12H
166P10	50	115 V 60 Hz.	10 C.T.	5	C13H
166R10	80	115 V 60 Hz.	10 C.T.	8	C15H
166S10	100	115 V 60 Hz.	10 C.T.	10	C16H
166P11	55	115 V 60 Hz.	11 C.T.	5	C13H
166S11	110	115 V 60 Hz.	11 C.T.	10	C16H
166C12	0.63	115 V 60 Hz.	6.3/12.6 C.T.	.1/.05	C2H
166E12	1.8	115 V 60 Hz.	12 C.T.	0.15	C3H
166F12B	3.6	115 V 60 Hz.	12 C.T.	0.3	C4H
166F12C	4.2	115 V 60 Hz.	12 C.T.	0.35	C4H
166GD12	8.4	117 V 50/60 Hz.	12	0.7	C7H
166JA12	12	115 V 60 Hz.	12 C.T.	1	C7H
166K12	14.4	115 V 60 Hz.	12 C.T.	1.2	C8H
166JB12	14.4	117 V 50/60 Hz.	12 C.T.	1.2	C9H

Part No.	VA	Primary	Secondary (R.M.S.)		Dim Ref.
			VAC	Amps	
166LA12	24	115 V 60 Hz.	12 C.T.	2	C9H
166N12B	48	117 V 50/60 Hz.	12 C.T.	4	C12H
166F12	3.78	115 V 60 Hz.	12.6 C.T.	0.3	C4H
166G12	6.3	115 V 60 Hz.	12.6 C.T.	0.5	C6H
166J12	12.6	115 V 60 Hz.	12.6 C.T.	1	C7H
166K12B	18.9	117 V 50/60 Hz.	12.6 C.T.	1.5	C10H
166L12B	25.2	117 V 50/60 Hz.	12.6 C.T.	2	C10H
166L12	31.5	115 V 60 Hz.	12.6 C.T.	2.5	C10H
166M12	37.8	117 V 50/60 Hz.	12.6 C.T.	3	C13H
166N12	50.4	115 V 60 Hz.	12.6 C.T.	4	C13H
166Q12	75.6	115 V 60 Hz.	12.6 C.T.	6	C14H
166R12	100.8	115 V 60 Hz.	12.6 C.T.	8	C16H
166E14	2.1	115 V 60 Hz.	14 C.T.	0.15	C3H
166G14	7	115 V 60 Hz.	14 C.T.	0.5	C6H
166J14	14	115 V 60 Hz.	14 C.T.	1	C7H
166L14	28	115 V 60 Hz.	14 C.T.	2	C10H
166Q14	84	115 V 60 Hz.	14 C.T.	6	C15H
166F16	4	115 V 60 Hz.	16 C.T.	0.25	C4H
166G16	8	115 V 60 Hz.	16 C.T.	0.50	C6H
166J16	16	115 V 60 Hz.	16 C.T.	1	C8H
166L16	35.2	115 V 60 Hz.	16 C.T.	2.2	C10H
166M16	48	115 V 60 Hz.	16 C.T.	3	C13H
166B18	0.54	115 V 60 Hz.	9/18 C.T.	.06/.03	C2H
166E18	5.4	115 V 60 Hz.	18 C.T.	0.3	C5H
166K18	27	115 V 60 Hz.	18 C.T.	1.5	C9H
166M18	54	115 V 60 Hz.	18 C.T.	3	C13H
166P18	90	115 V 60 Hz.	18 C.T.	5	C15H
166D20	2	115 V 60 Hz.	20 C.T.	0.1	C3H
166E20	3	115 V 60 Hz.	20 C.T.	0.15	C3H
166F20	6	115 V 60 Hz.	20 C.T.	0.3	C5H
166G20	10	115 V 60 Hz.	20 C.T.	0.5	C7H
166J20	20	115 V 60 Hz.	20 C.T.	1	C9H
166L20	40	115 V 60 Hz.	20 C.T.	2	C11H
166L22	44	115 V 60 Hz.	22 C.T.	2	C13H
166A24	0.63	115 V 60 Hz.	12.6/25.2 C.T.	.05/.025	C2H
166C24	2.04	115 V 60 Hz.	24 C.T.	0.085	C3H
166EA24	4.8	115 V 60 Hz.	24 C.T.	0.2	C5H
166FB24	9.6	117 V 50/60 Hz.	24 C.T.	0.4	C7H
166GD24B	16.8	117 V 50/60 Hz.	24 C.T.	0.7	C9H
166J24	24	117 V 50/60 Hz.	24 C.T.	1	C10H
166JB24	24	115 V 60 Hz.	24 C.T.	1	C9H
166L24	48	115 V 60 Hz.	24 C.T.	2	C13H
166M24	72	115 V 60 Hz.	24 C.T.	3	C14H
166N24	96	115 V 60 Hz.	24 C.T.	4	C16H
166D25	2.5	115 V 60 Hz.	25 C.T.	0.1	C3H
166E25	3.75	115 V 60 Hz.	25 C.T.	0.15	C4H
166F25	7.5	115 V 60 Hz.	25 C.T.	0.3	C6H
166G25	12.5	115 V 60 Hz.	25 C.T.	0.5	C7H
166J25	25	115 V 60 Hz.	25 C.T.	1	C9H
166J25B	25	117 V 50/60 Hz.	25 C.T.	1	C10H
166K25	37.5	115 V 60 Hz.	25 C.T.	1.5	C11H
166L25	50	115 V 60 Hz.	25 C.T.	2	C13H
166M25	75	115 V 60 Hz.	25 C.T.	3	C14H
166L25B	50.4	115 V 50/60 Hz.	25.2 C.T.	2	C14H
166F28	7	115 V 60 Hz.	28 C.T.	0.25	C6H
166G28	14	115 V 60 Hz.	28 C.T.	0.5	C7H



Part No.	VA	Primary	Secondary (R.M.S.)		Dim Ref.
			VAC	Amps	
166J28	28	115 V 60 Hz.	28 C.T.	1	C10H
166L28	56	115 V 60 Hz.	28 C.T.	2	C13H
166E30	4.5	115 V 60 Hz.	30 C.T.	0.15	C4H
166F30	7.5	115 V 60 Hz.	30 C.T.	0.25	C6H
166G30	15	115 V 60 Hz.	30 C.T.	0.5	C8H
166J33	33	115 V 60 Hz.	33 C.T.	1	C10H
166K35	52.5	115 V 60 Hz.	35 C.T.	1.5	C13H
166E36	5.4	115 V 60 Hz.	36 C.T.	0.15	C5H
166F36	10.8	115 V 60 Hz.	36 C.T.	0.3	C7H
166G36	18	115 V 60 Hz.	36 C.T.	0.5	C8H
166J36	36	115 V 60 Hz.	36 C.T.	1	C11H
166L42	84	115 V 60 Hz.	42 C.T.	2	C15H
166E44	6.6	115 V 60 Hz.	44 C.T.	0.15	C6H
166F44	11	115 V 60 Hz.	44 C.T.	0.25	C7H
166G44	22	115 V 60 Hz.	44 C.T.	0.5	C9H
166J44	44	115 V 60 Hz.	44 C.T.	1	C12H
166M48	144	117 V 50/60 Hz.	48 C.T.	3	B1H
166C50	3.75	115 V 60 Hz.	50 C.T.	0.075	C4H
166F50	15	115 V 60 Hz.	50 C.T.	0.3	C8H
166G50	25	115 V 60 Hz.	50 C.T.	0.5	C9H
166J50	50	115 V 60 Hz.	50 C.T.	1	C13H
166L50	100	115 V 60 Hz.	50 C.T.	2	C16H
166G60	30	115 V 60 Hz.	60 C.T.	0.5	C10H
166M72	216	117 V 50/60 Hz.	72 C.T.	3	B2H
166G80	40	115 V 60 Hz.	80 C.T.	0.5	C11H
166G100	50	115 V 60 Hz.	100 C.T.	0.5	C13H
166F120	36	115 V 60 Hz.	120 C.T.	0.3	C11H

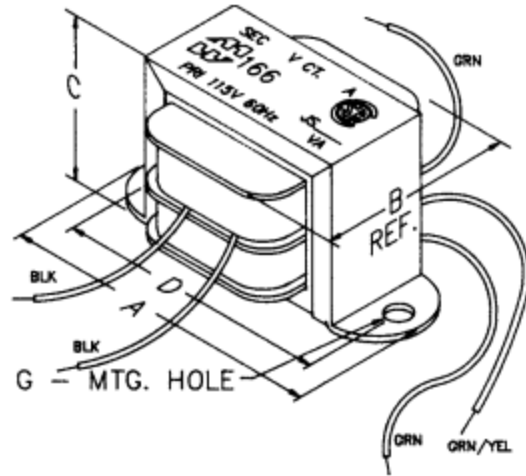

Dimension Table "C" Mount

Mtg. Style	Dimensions (Inches)				Mtg. Hole (Inches)
	A	B	C	D	
C0H	1.35	0.69	0.69	1.06	0.125
C1H	1.63	0.88	0.81	1.38	0.125
C2H	2.06	1.25	1.19	1.75	0.187
C3H	2.06	1.38	1.19	1.75	0.187
C4H	2.38	1.38	1.38	2.00	0.187
C5H	2.38	1.50	1.38	2.00	0.187
C6H	2.81	1.50	1.69	2.38	0.187
C7H	2.81	1.63	1.69	2.38	0.187
C8H	3.25	1.63	2.00	2.81	0.187
C9H	3.25	1.75	2.00	2.81	0.187
C10H	3.25	2.00	2.00	2.81	0.187
C11H	3.69	1.88	2.31	3.13	0.187
C12H	3.69	2.00	2.31	3.13	0.187
C13H	3.69	2.13	2.31	3.13	0.187
C14H	4.03	2.25	2.63	3.56	0.187
C15H	4.03	2.50	2.63	3.56	0.187
C16H	4.50	2.50	3.00	4.00	0.203

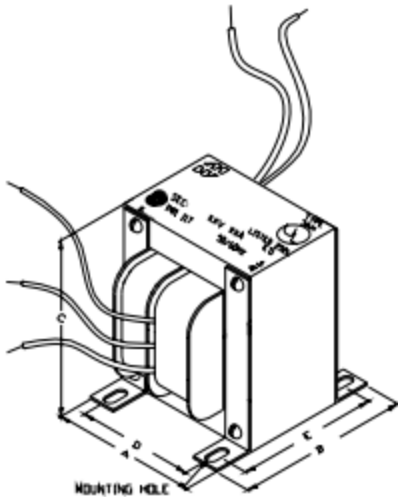

Dimension Table "B" Mount

Mtg. Style	Dimensions (Inches)					Mtg. Slot (Inches)
	A	B	C	D	E	

B1H	3.44	2.98	4.13	2.75	2.38	0.203 x 0.375
B2H	3.75	3.56	4.50	3.00	3.00	0.203 x 0.375